

THIS DRAWING IS UNPUBLISHED. RELEASED FOR PUBLICATION ,19 .
 © COPYRIGHT 19 BY AMP INCORPORATED. ALL RIGHTS RESERVED.

LOC	QTY	REVISIONS				
P	LTR	DESCRIPTION	DATE	DWN	APVD	
BD	36	F	REDRAWN PER EC 0020-930-95	20 SEP 95	-	-

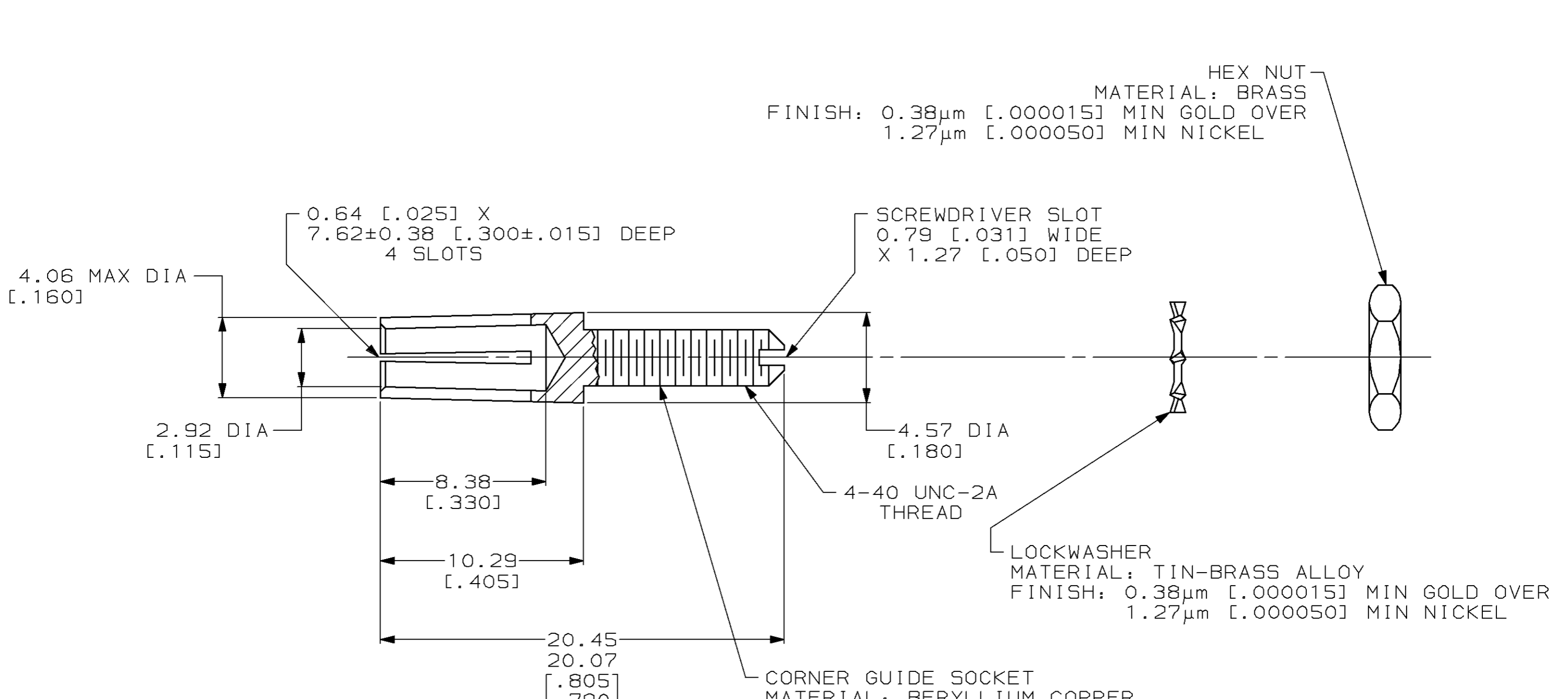

HEX NUT
 MATERIAL: BRASS
 FINISH: 0.38µm [.000015] MIN GOLD OVER
 1.27µm [.000050] MIN NICKEL

SCREWDRIVER SLOT
 0.79 [.031] WIDE
 X 1.27 [.050] DEEP

0.64 [.025] X
 7.62±0.38 [.300±.015] DEEP
 4 SLOTS

4.06 MAX DIA
 [.160]

2.92 DIA
 [.115]

8.38
 [.330]

10.29
 [.405]

20.45
 20.07
 [.805]
 [.790]

4.57 DIA
 [.180]

4-40 UNC-2A
 THREAD

LOCKWASHER
 MATERIAL: TIN-BRASS ALLOY
 FINISH: 0.38µm [.000015] MIN GOLD OVER
 1.27µm [.000050] MIN NICKEL

CORNER GUIDE SOCKET
 MATERIAL: BERYLLIUM COPPER
 FINISH: 0.38µm [.000015] MIN GOLD OVER
 1.27µm [.000050] MIN NICKEL

202512-1
 PART
 NUMBER

THIS DRAWING IS A CONTROLLED DOCUMENT FOR AMP INCORPORATED. IT IS SUBJECT TO CHANGE AND THE CONTROLLING ENGINEERING ORGANIZATION SHOULD BE CONTACTED FOR THE LATEST REVISION.		DWN C. DORWART 20 SEP 95	AMP AMP Incorporated Harrisburg, PA 17105-3608
DIMENSIONS: mm [INCHES]		CHK R. STONE 25 SEP 95	
TOLERANCES UNLESS OTHERWISE SPECIFIED: 0 PLC ±- 1 PLC ±- 2 PLC ±0.13 [.005] 3 PLC ±- 4 PLC ±- ANGLES ±- FINISH		APVD G. STEINHAUER 04 OCT 95	NAME CORNER GUIDE SOCKET ASSEMBLY, UNASSEMBLED, M SERIES
MATERIAL SEE CALLOUTS		PRODUCT SPEC - APPLICATION SPEC - WEIGHT -	SIZE A3
SEE CALLOUTS		CUSTOMER DRAWING	CAGE CODE 00779
			DRAWING NO C=202512
			SCALE 5:1
			SHEET 1 OF 1
			REV F