

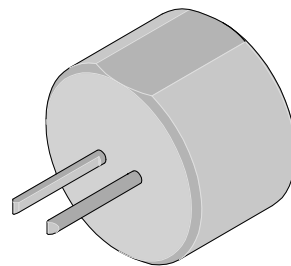

Extractor Tool Instruction Sheet Order No. 63813-2400



FEATURES

- This Extractor Tool is for the removal of 98913 & 64322 Series female terminals from CMC connector.

SCOPE

Products: 0.6mm (.02") CP Crimp Terminal for CMC connector.

Terminal Series No.	Terminal Order No.	
98913	98913-1019	98913-1229
	98913-1029	98913-1319
	98913-1219	98913-1329
64322	64322-1019	64322-1229
	64322-1029	64322-1319
	64322-1219	64322-1329

OPERATION:

When removing a damaged crimped wire from the CMC connector follow the steps below:

1. The secondary lock on the CMC connector will need to be opened first. See Figure 1.
2. Using a screwdriver insert the flat edge under the tab of the secondary lock and pull up. Use your fingers to open the lock completely.

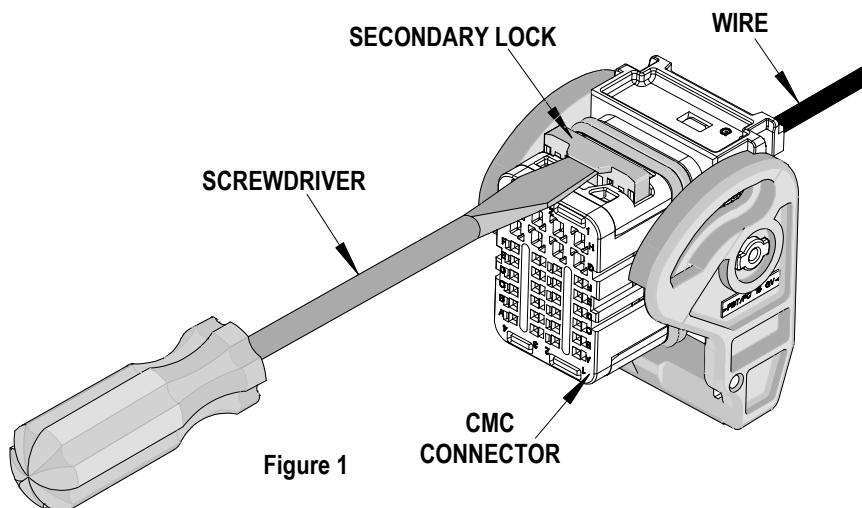

3. Position the blades of the extraction tool into the two small cavities of the slot in the front face of the housing as shown in Figure 2. Use the identifying markings on both the front and back of the connector to locate the opening used to extract the crimped wire.

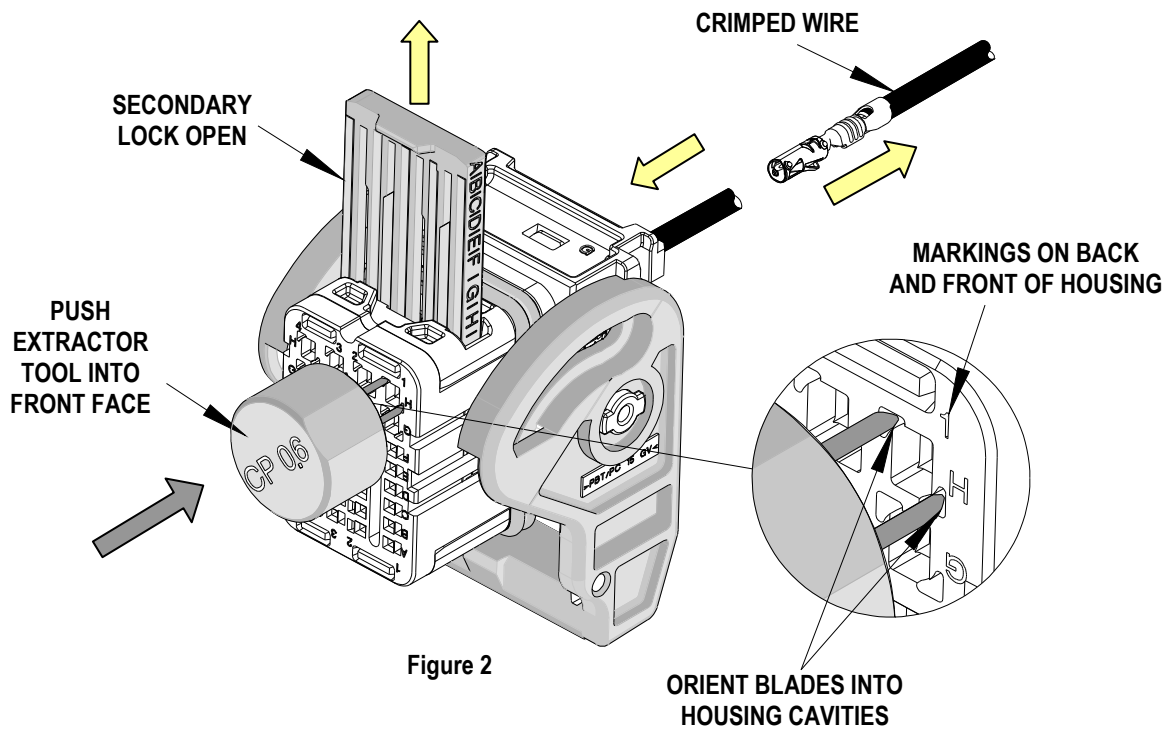

Figure 2

4. Push extractor tool into the desired slot until it clicks or comes to a stop. Do not force the extractor tool any further or there can be damage to the housing.
5. Gently push the wire forward towards the housing and then pull out of the CMC housing.
6. Molex does not offer repair parts for Extractor Tools due to the inexpensive nature of these tools.

Americas Headquarters
Lisle, Illinois 60532 U.S.A.
1-800-78MOLEX
amerinfo@molex.com

Far East North Headquarters
Yamato, Kanagawa, Japan
81-462-65-2324
feninfo@molex.com

Far East South Headquarters
Jurong, Singapore
65-6-268-6868
fesinfo@molex.com

European Headquarters
Munich, Germany
49-89-413092-0
eurinfo@molex.com

Corporate Headquarters
2222 Wellington Ct.
Lisle, IL 60532 U.S.A.
630-969-4550
Fax: 630-969-1352

Visit our Web site at <http://www.molex.com>