



MIC2253

3.5A 1MHz High Efficiency Boost Regulator with OVP and Softstart

General Description

The MIC2253 is a high power density 1MHz PWM DC/DC boost regulator. The 3.5A minimum switch current limit combined with a 1MHz switching frequency allows the MIC2253 to use smaller inductors and deliver high power in a tiny solution size.

The 2.5V to 10V input voltage range of MIC2253 allows direct operation from 1 and 2 cell Li-ion as well as 3 to 4 cell NiCad, NiMH, Alkaline or lithium batteries. Maximum battery life is assured with a low 0.1 μ A shutdown current.

The MIC2253 is available in a low profile 12-pin 3mm x 3mm MLF[®] package. To prevent a high inrush current, a minimum 1ms soft-start period is set by default and the MIC2253 has the ability to extend the soft-start period with an external capacitor.

Datasheet and support documentation can be found on Micrel's web site at: www.micrel.com.

Features

- 3.5A minimum switch current
- 1.245V \pm 3% feedback voltage
- 2.5V to 10V input voltage
- Output over-voltage protection (OVP)
- Externally programmable soft-start
- Output voltage up to 30V (max)
- Fixed 1MHz operation
- <1% line regulation
- 0.1 μ A shutdown current
- Over temperature protection
- Under-voltage lockout (UVLO)
- 12-pin 3mm x 3mm leadless MLF[®] package
- -40 $^{\circ}$ C to +125 $^{\circ}$ C junction temperature range

Applications

- Mobile handsets
- Portable media/MP3 players
- Portable navigation devices (GPS)
- WiFi/WiMax/WiBro modules
- Digital Cameras
- Wireless LAN cards
- USB powered devices
- Portable applications

Typical Application

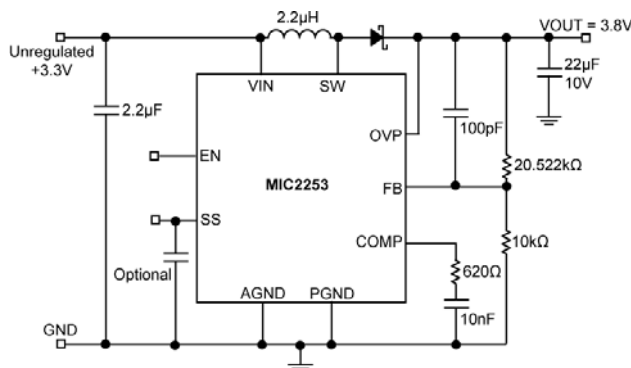

MLF and MicroLeadFrame are registered trademarks of Amkor Technology, Inc.

Micrel Inc. • 2180 Fortune Drive • San Jose, CA 95131 • USA • tel +1 (408) 944-0800 • fax + 1 (408) 474-1000 • <http://www.micrel.com>

Ordering Information

Part Number	Marking Code ⁽²⁾	OVP	Junction Temp. Range	Package	Lead Finish
MIC2253-06YML	06 2253	6V	-40° to +125°C	12-Pin 3x3 MLF [®]	Pb-Free

Note: MLF[®] is a GREEN RoHS compliant package. Lead finish is NiPdAu. Mold compound is Halogen Free.

Pin Configuration

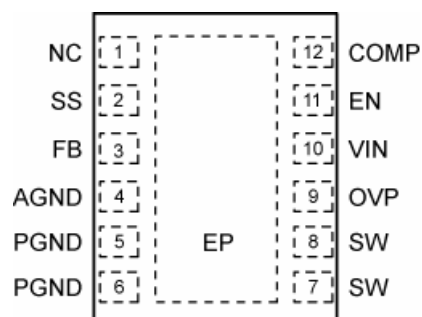

12-Pin 3mm x 3mm MLF[®] (ML)
(Top View)

Pin Description

Pin Number	Pin Name	Pin Function
1	NC	No connect. Not internally connected.
2	SS	Soft start (Input). Connect a capacitor to GND to slowly turn on the device. The higher the capacitance, the longer the turn-on time.
3	FB	Feedback (Input): Output voltage sense node. Connect external resistors to set the output voltage. Nominal feedback voltage is 1.245V.
4	AGND	Analog Ground
5,6	PGND	Power Ground
7,8	SW	Switch Node: Internal power BIPOLAR collector.
9	OVP	Over-Voltage Protection (OVP): Connect to the output voltage to clamp the maximum output voltage. A resistor divider from this pin to ground could be used to raise the OVP level beyond 6V (max).
10	VIN	Supply (Input): 2.5V to 10V for internal circuitry.
11	EN	Enable (Input): Applying 1.5V or greater enables the regulator. Applying a voltage of 0.4V or less disables the MIC2253. Do not leave floating.
12	COMP	Compensation pin (Input): Add external R and C to GND to stabilize the converter.
EP	HS Pad	Exposed Heat-Sink pad.

Absolute Maximum Ratings⁽¹⁾

Supply Voltage (V_{IN})	12V
Switch Voltage (V_{SW})	-0.3V to 34V
Enable Voltage (V_{EN})	-0.3V to 12V
FB Voltage (V_{FB})	6V
Switch Current (I_{SW})	Internally Limited
Ambient Storage Temperature (T_s)	-65°C to +150°C
ESD Rating ⁽³⁾	2kV

Operating Ratings⁽²⁾

Supply Voltage (V_{IN})	2.5V to 10V
Enable Voltage (V_{EN})	0V to V_{IN}
Junction Temperature (T_J)	-40°C to +125°C
Package Thermal Impedance	
3mm x 3mm MLF-12 (θ_{JA})	60°C/W

Electrical Characteristics⁽⁴⁾

$T_A = 25^\circ\text{C}$; $V_{IN} = V_{EN} = 3.6\text{V}$; unless otherwise noted. **Bold** values indicate $-40^\circ\text{C} \leq T_J \leq +125^\circ\text{C}$.

Symbol	Parameter	Condition	Min	Typ	Max	Units
V_{IN}	Supply Voltage Range		2.5		10	V
V_{UVLO}	Under-Voltage Lockout		1.8	2.1	2.4	V
V_{OVP}	Over-Voltage Protection		5.25	5.6	6.3	V
I_{VIN}	Quiescent Current	$V_{FB} > 1.245\text{V}$, Not Switching		15	23	mA
I_{SD}	Shutdown Current	$V_{EN} = 0\text{V}^{(5)}$		0.1	1	μA
V_{FB}	Feedback Voltage		1.208	1.245	1.283	V
I_{FB}	Feedback Input Current	$V_{FB} = 1.245\text{V}$		-450		nA
	Line Regulation	$3.0\text{V} \leq V_{IN} \leq 4.5\text{V}$		0.5		%
D_{MIN}	Minimum Duty Cycle			10		%
D_{MAX}	Maximum Duty Cycle			90		%
I_{SW}	Switch Current Limit	$V_{IN} = 3.6\text{V}$	3.5	4.75	8	A
V_{SW}	Switch Saturation Voltage	$V_{IN} = 3.6\text{V}$, $I_{SW} = 3.5\text{A}$		350	500	mV
I_{SW}	Switch Leakage Current	$V_{EN} = 0\text{V}$, $V_{SW} = 10\text{V}$		0.01	10	μA
V_{EN}	Enable Threshold	TURN ON	1.5			V
		TURN OFF			0.4	
I_{EN}	Enable Pin Current	$V_{EN} = 10\text{V}$		20	40	μA
f_{SW}	Oscillator Frequency		0.8	1	1.2	MHz
I_{SS}	Soft start	$V_{SS} = 0\text{V}$		30		μA
T_J	Over-Temperature Threshold Shutdown			150		$^\circ\text{C}$
		Hysteresis		10		$^\circ\text{C}$

Notes:

1. Absolute maximum ratings indicate limits beyond which damage to the component may occur. Electrical specifications do not apply when operating the device outside of its operating ratings. The maximum allowable power dissipation is a function of the maximum junction temperature, $T_{J(\text{Max})}$, the junction-to-ambient thermal resistance, θ_{JA} , and the ambient temperature, T_A . The maximum allowable power dissipation will result in excessive die temperature, and the regulator will go into thermal shutdown.
2. The device is not guaranteed to function outside its operating rating.
3. Devices are ESD sensitive. Handling precautions recommended. Human Body Model, 1.5k Ω in series with 100pF.
4. Specification for packaged product only.
5. $I_{SD} = I_{VIN}$

Typical Characteristics

Efficiency $V_{OUT} = 3.8V$

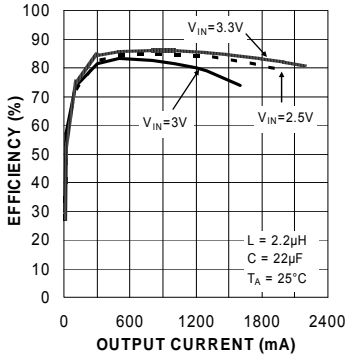

Efficiency $V_{OUT} = 5.0V$

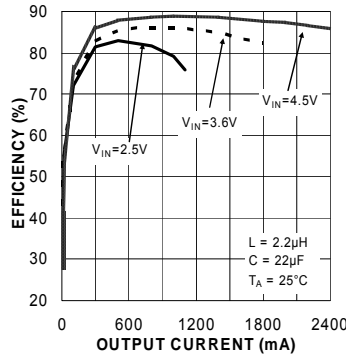

Efficiency $V_{OUT} = 12.0V$

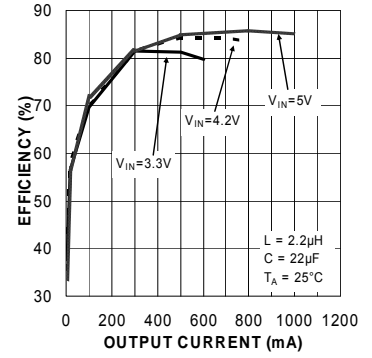

Efficiency $V_{OUT} = 15.0V$

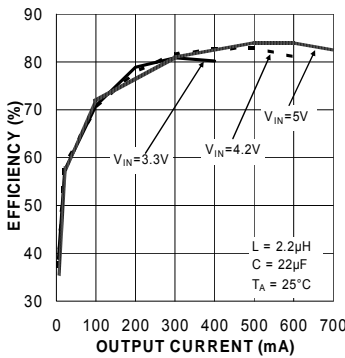

Quiescent Current vs. Temperature

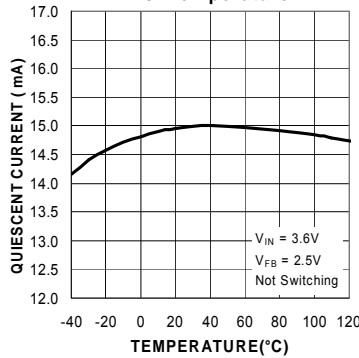

Quiescent Current vs. Input Voltage

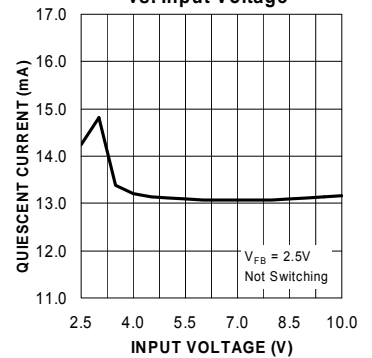

Frequency vs. Input Voltage

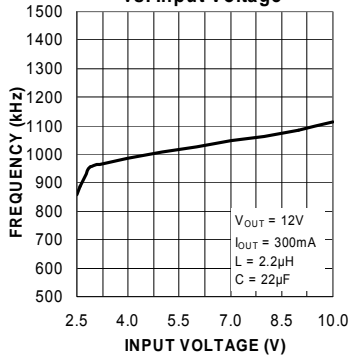

Frequency vs. Temperature

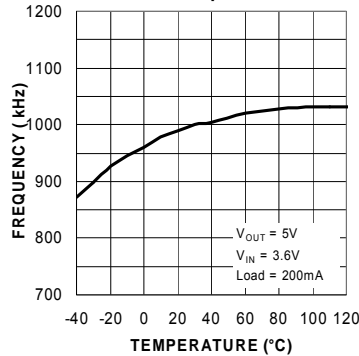

Feedback Voltage vs. Temperature

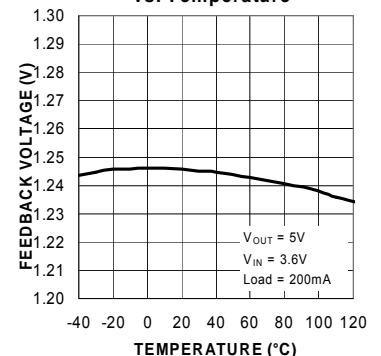

Load Regulation

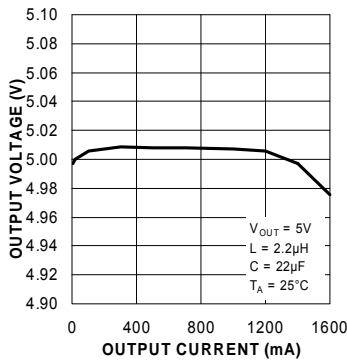

Line Regulation

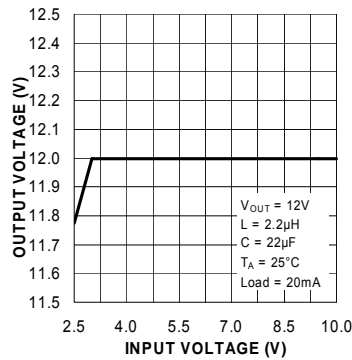

Current Limit vs. Input Voltage

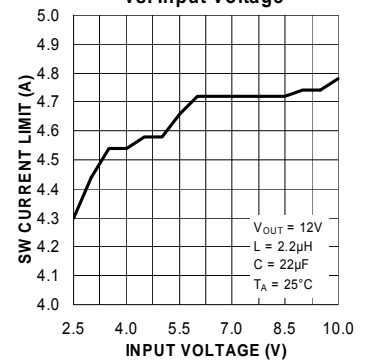

Typical Characteristics (Continued)

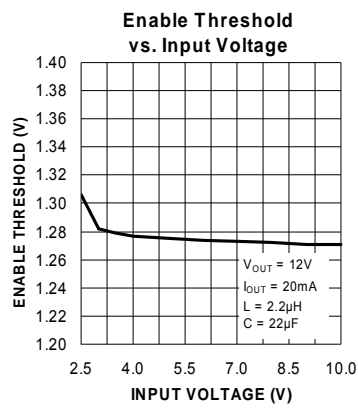
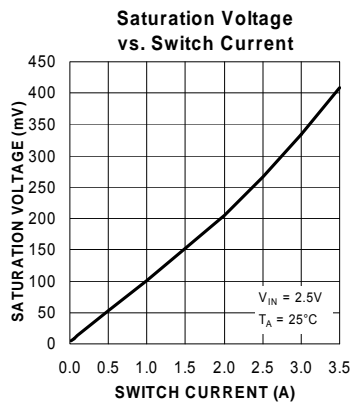

Functional Characteristics

Enable Turn-On

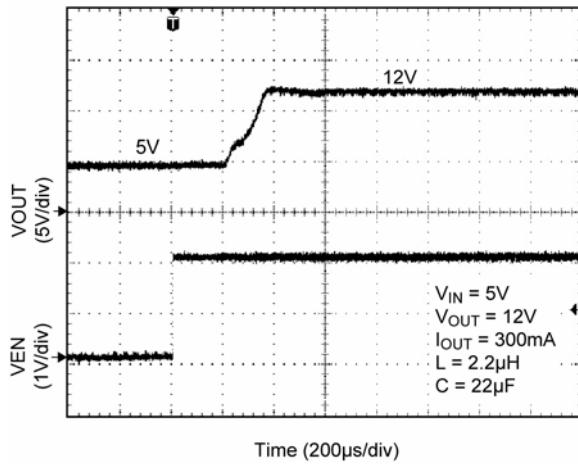

Input Turn-On

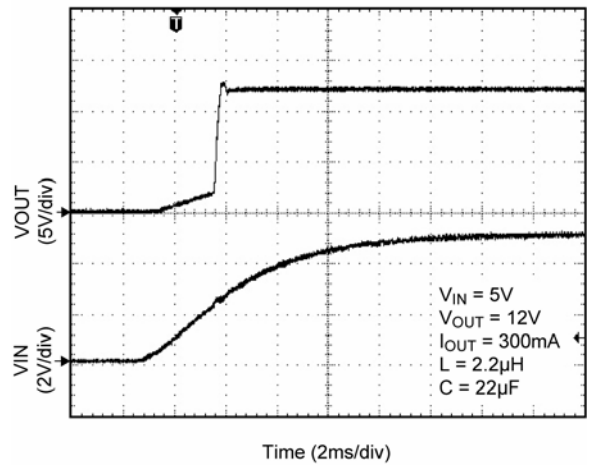

Switching Waveform

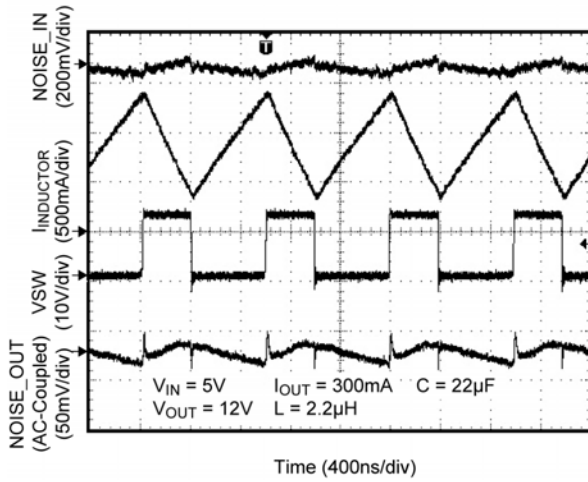

Line Transient

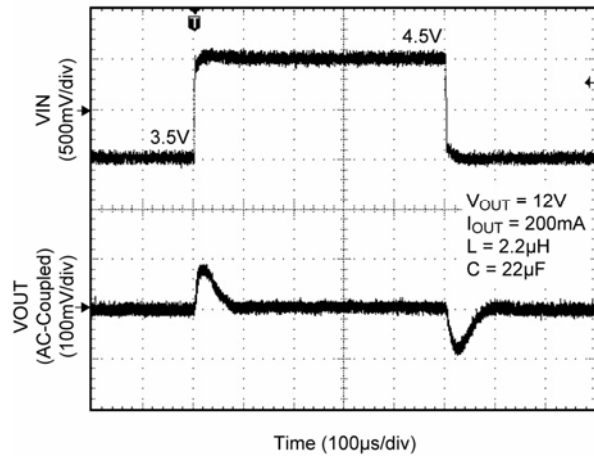

Load Transient (12V Output)

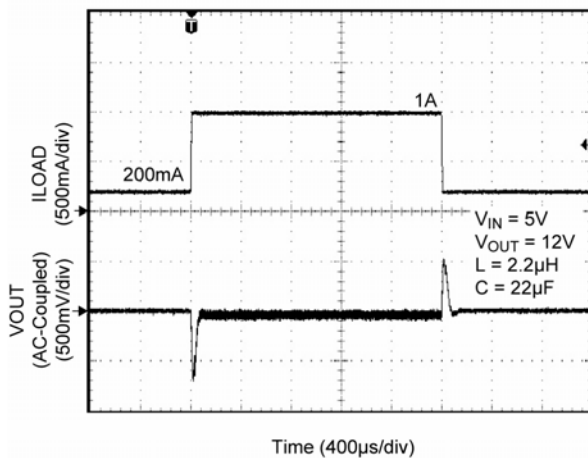

Load Transient (5V Output)

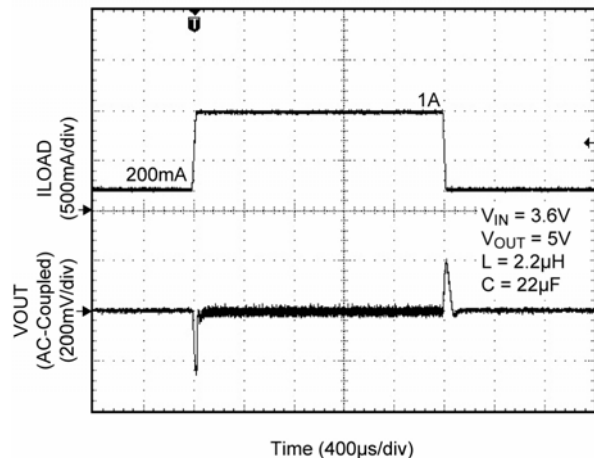

Functional Diagram

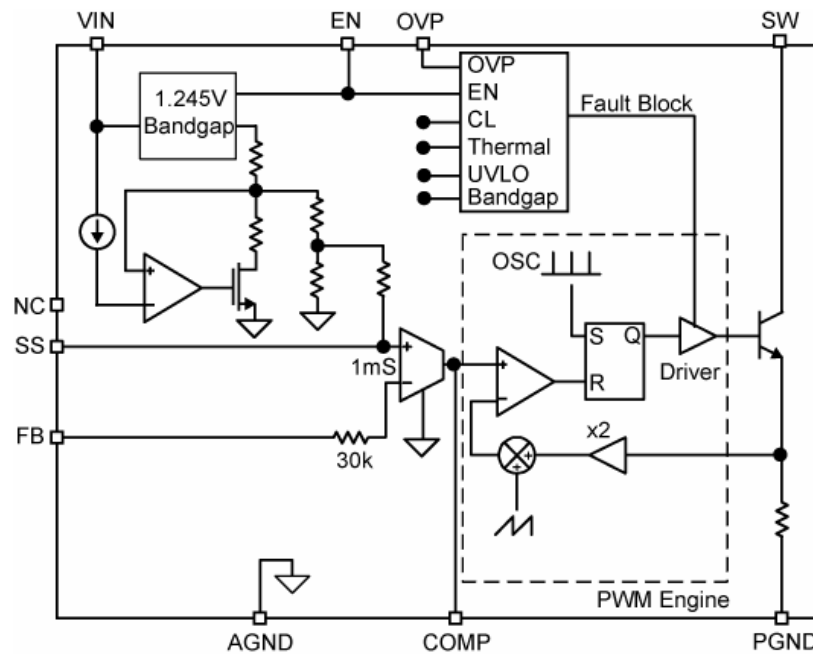

Functional Description

The MIC2253 is a constant frequency, pulse-width-modulated (PWM) peak current-mode step-up regulator. The device's simplified control scheme is illustrated in the block diagram above. A reference voltage is fed into the PWM engine where the duty cycle output of the constant frequency PWM engine is computed from the error, or difference, between the REF and FB voltages. The PWM engine encompasses the necessary circuit blocks to implement a current-mode boost switching power supply. The necessary circuit blocks include, but are not limited to, an oscillator/ramp generator, slope compensation ramp generator, g_m error amplifier, current amplifier, PWM comparator, and drive logic for the internal 3.5A bipolar power transistor.

Inside the PWM engine, the oscillator functions as a trigger for the PWM comparator that turns on the bipolar power transistor and resets the slope compensation ramp generator. The current amplifier is used to measure the power transistor's current by amplifying the voltage signal from the sense resistor connected to the emitter of the bipolar power transistor. The output of the current amplifier is summed with the output of the slope compensation ramp generator where the result is connected to one of the inputs of the PWM comparator.

The g_m error amplifier measures the feedback voltage through the external resistor and amplifies the error between the detected voltage signal from the feedback and the internal reference voltage. The output of the g_m error amplifier provides the voltage loop signal that is fed to the other input of the PWM comparator. When the current loop signal exceeds the voltage loop signal the PWM comparator turns off the power transistor. The next oscillator/clock period initiates the next switching cycle, maintaining the constant frequency current-mode PWM control. The enable pin shuts down the output switching and disables control circuitry to reduce input current-to-leakage levels. Enable pin input current is approximately zero, at zero volts.

DC-to-DC PWM Boost Conversion

The MIC2253 is a constant-frequency boost converter. It can convert a low DC input voltage to a high DC output voltage. Figure 1 shows a typical circuit. Boost regulation is achieved by turning on an internal switch, which draws current through the inductor. When the switch turns off, the inductor's magnetic field collapses. This causes the current to be discharged into the output capacitor through an external Schottky diode. The Functional Characteristics show Input Voltage ripple, Output Voltage ripple, SW Voltage, and Inductor Current for 300mA load current. Regulation is achieved by modulating the pulse width i.e., pulse-width modulation (PWM).

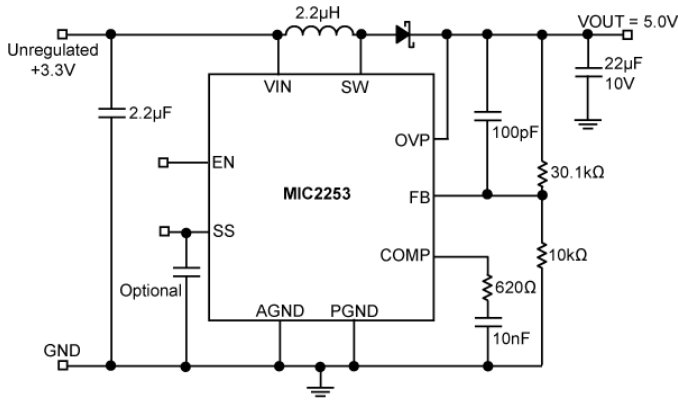

Figure 1. Typical Application Circuit

Duty Cycle Considerations

Duty cycle refers to the switch on-to-off time ratio and can be calculated as follows for a boost regulator:

$$D = 1 - \frac{V_{IN}}{V_{OUT}}$$

However at light loads, the inductor will completely discharge before the end of a switching cycle. The current in the inductor reaches zero before the end of the switching cycle. This is known as discontinuous conduction mode (DCM). DCM occurs when:

$$I_{OUT} < \frac{V_{IN}}{V_{OUT}} \times \frac{I_{PEAK}}{2}$$

where

$$I_{PEAK} < \frac{(V_{OUT} - V_{IN})}{L \times f} \times \left(\frac{V_{IN}}{V_{OUT}} \right)$$

In DCM, the duty cycle is smaller than in continuous conduction mode. In DCM the duty cycle is given by:

$$D = \frac{f \times \sqrt{2 \times L \times I_{OUT} \times (V_{OUT} - V_{IN})}}{V_{IN}}$$

The duty cycle required for voltage conversion should be less than the maximum duty cycle of 90%. Also, in light load conditions where the input voltage is close to the output voltage, the minimum duty cycle can cause pulse skipping. This is due to the energy stored in the inductor causing the output to slightly overshoot the regulated output voltage. During the next cycle, the error amplifier detects the output as being high and skips the following pulse. This effect can be reduced by increasing the minimum load or by increasing the inductor value. Increasing the inductor value also reduces the peak current. Minimum duty cycle is typically 10%.

Over-Voltage Protection (OVP)

The MIC2253 provides a fixed 5.6V overvoltage protection. The overvoltage functionality will clamp the output voltage to a safe level in the event that a fault condition causes the output voltage to increase beyond control. To ensure the highest level of protection, the MIC2253 OVP pin will shut the switch off when an overvoltage condition is detected, saving itself, the output capacitor, and downstream devices from damage. Two external resistors can be used to change the OVP from the range of 6V to 30V. Be careful not to exceed the 30V rating of the switch. The OVP feature may be disabled by grounding the OVP pin.

The OVP pin is connected internally to a reference voltage via a voltage divider circuit. For a 5.6V OVP setting, connect the OVP pin directly to the output voltage as shown in Figure 1. To increase the OVP voltage above 5.6V, an external parallel resistor network can be configured, as shown in Figure 2, with the following equation:

$$V_{OVP} = 1.245 \times \frac{67k \times (R1 + R2)}{15k \times R2}$$

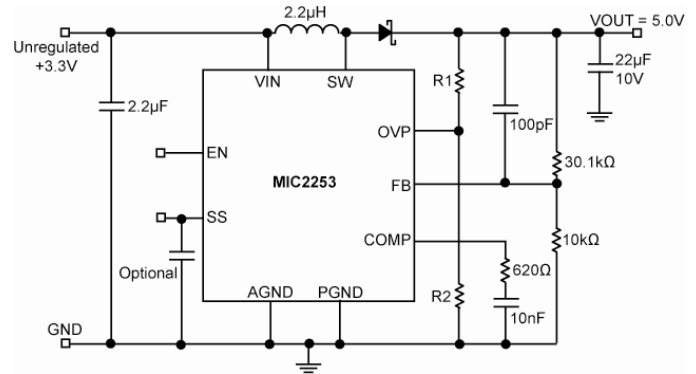

Figure 2. Adjustable OVP Circuit

Note:

1. The maximum value of R2 is 30kΩ.

Soft Start Functionality

The soft start time is dependant up on both C_{SS} and the comp capacitor values. C_{COMP} is fixed for stable operation (typically 10nF); therefore, if any increases in soft start are desired, this should be done using the C_{SS} capacitor. The approximate total startup time is given by:

$$T_{SS} = 1ms + 85k \times C_{SS}$$

Component Selection

Inductor

The MIC2253 is designed to work with a 2.2μH inductor. This is due to the unavoidable “right half plane zero” effect for the continuous current boost converter topology. The frequency at which the right half plane zero occurs can be calculated as follows:

$$f_{\text{rhpz}} = \frac{V_{\text{IN}}^2}{V_{\text{OUT}} \times L \times I_{\text{OUT}} \times 2\pi}$$

The right half plane zero has the undesirable effect of increasing gain, while decreasing phase. This requires that the loop gain is rolled off before this has significant effect on the total loop response. This can be accomplished by either reducing inductance (increasing RHPZ frequency) or increasing the output capacitor value (decreasing loop gain).

Output Capacitor

Output capacitor selection is a trade-off between performance, size, and cost. Increasing output capacitance will lead to an improved transient response, but also an increase in size and cost. X5R or X7R dielectric ceramic capacitors are recommended for designs with the MIC2253.

The output capacitor sets the frequency of the dominant pole and zero in the power stage. The zero is given by:

$$f_z = \frac{1}{C \times R_{\text{ESR}} \times 2\pi}$$

For ceramic capacitors, the ESR is very small. This puts the zero at a very high frequency where it can be ignored. Fortunately, the MIC2253 is current mode in operation which reduces the need for this output capacitor zero when compensating the feedback loop.

The frequency of the pole caused by the output capacitor is given by:

$$f_p = \frac{I_{\text{OUT}}}{C \times V_{\text{OUT}} \times 2 \times \pi}$$

Diode Selection

The MIC2253 requires an external diode for operation. A Schottky diode is recommended for most applications due to their lower forward voltage drop and reverse recovery time. Ensure the diode selected can deliver the peak

inductor current and the maximum reverse voltage is rated greater than the output voltage.

Input Capacitor

A minimum 2.2μF ceramic capacitor with an X5R or X7R dielectric is recommended for designing with the MIC2253. Increasing input capacitance will improve performance and greater noise immunity on the source. The input capacitor should be as close as possible to the inductor and the MIC2253, with short traces for good noise performance.

Compensation

The comp pin is connected to the output of the voltage error amplifier. The voltage error amplifier is a transconductance amplifier. Adding a series RC-to-ground adds a zero at:

$$f_{\text{zero}} = \frac{1}{2\pi R_2 C_4}$$

The resistor should be set to approximately 600Ω. The capacitor typically ranges from 10nF to 100nF.

Adding an optional capacitor from comp pin-to-ground adds a pole at approximately:

$$f_{\text{pole}} = \frac{1}{2\pi R_2 C_3}$$

This capacitor typically is 100pF. Generally, an RC to ground is all that is needed. The RC should be placed as close as possible to the compensation pin. The capacitor should be a ceramic with a X5R, X7R, or COG dielectric. Refer to the MIC2253 evaluation board document for component location.

Feedback Resistors

The feedback pin (FB) provides the control path to the control the output. The FB pin is used to compare the output to an internal reference. Output voltages are adjusted by selecting the appropriate feedback network values. The desired output voltage can be calculated as follows:

$$V_{\text{OUT}} = V_{\text{REF}} \cdot \left(\frac{R_1}{R_2} + 1 \right)$$

where V_{REF} is equal to 1.245V.

MIC2253 Sample Schematic

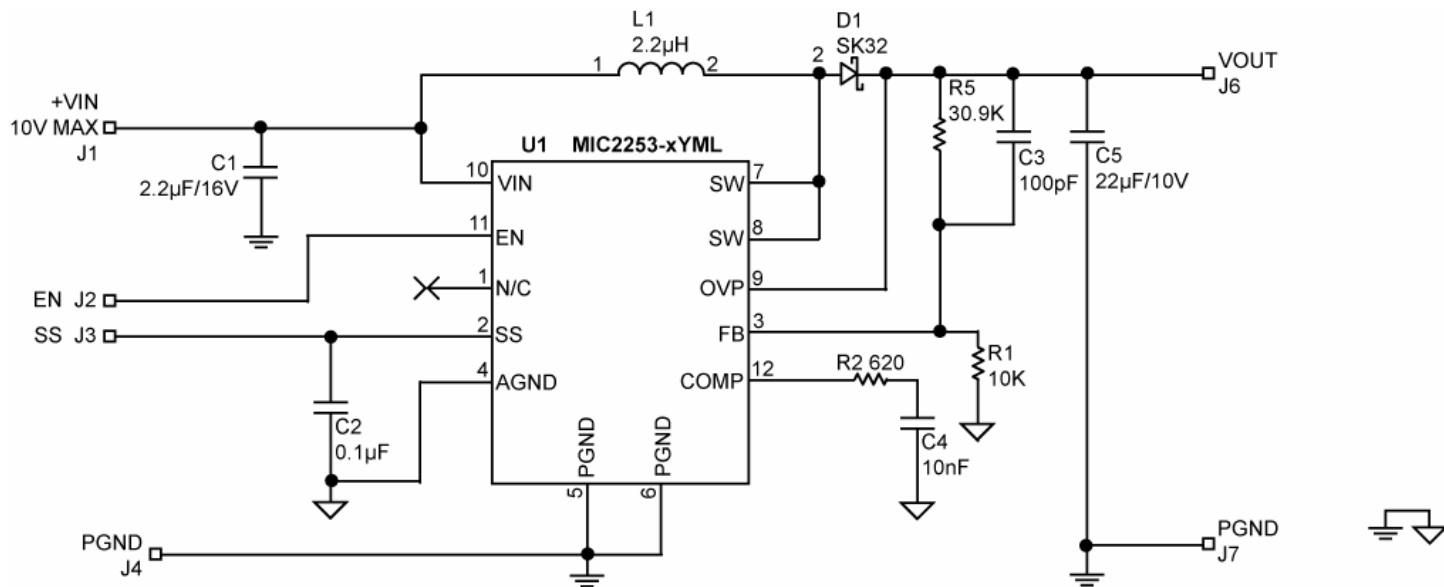

Bill of Materials

Item	Part Number	Manufacturer	Description	Qty.
C1	C1608X5R1C225K	TDK ⁽¹⁾	Capacitor, 2.2 μ F, 16V, X5R, 0603 size	1
	GRM188R61C225KE15	Murata ⁽²⁾	Capacitor, 2.2 μ F, 16V, X5R, 0603 size	
	CL10A225K08NNN	Samsung ⁽³⁾	Capacitor, 2.2 μ F, 16V, X5R, 0603 size	
C2	C1608X7R1H104K/10	TDK	Capacitor, 0.1 μ F, 16V, X7R, 0603 size	1
	GRM188R71H104KA93	Murata	Capacitor, 0.1 μ F, 16V, X7R, 0603 size	
	CL10B104KB8NNN	Samsung	Capacitor, 0.1 μ F, 16V, X7R, 0603 size	
C3	C1608C0G1H101J	TDK	Capacitor, 100pF, 50V, C0G, 0603 size	1
	GRM1885C1H101JA01	Murata	Capacitor, 100pF, 50V, C0G, 0603 size	
	CL10C101JB8NNN	Samsung	Capacitor, 100pF, 50V, C0G, 0603 size	
	06035A101AT2A	AVX ⁽⁴⁾	Capacitor, 100pF, 50V, C0G, 0603 size	
C4	C1608X5R1H103K	TDK	Capacitor, 10nF, 50V, X5R, 0603 size	1
	CL10B103KB8NNN	Samsung	Capacitor, 10nF, 50V, X5R, 0603 size	
	06035C103KA12A	AVX	Capacitor, 10nF, 50V, X5R, 0603 size	
C5	CL21A226MPCLRNC	Samsung	Capacitor, 22 μ F, 10V, X5R, 0805 size	1
	LMK212BJ226MG-T	Taiyo Yuden ⁽⁵⁾	Capacitor, 22 μ F, 10V, X5R, 0805 size	
D1	SK32	MCC ⁽⁶⁾	Schottky Diode, 3A, 20V	1
	SK34	MCC	Schottky Diode, 3A, 40V	
L1	LTF5022T-2R2N3R2	TDK	Inductor, 2.2 μ H, 3.4A, 5.2 x 5.0 x 2.2mm	1
	RLF7030T-2R2M	TDK	Inductor, 2.2 μ H, 5.4A, 6.8 x 7.3 x 3.2mm	
	MOS6020-222ML	Coilcraft ⁽⁷⁾	Inductor, 2.2 μ H, 3.56A, 6.0 x 7.1 x 2.4mm	
R1	CRCW06031002FRTI	Vishay ⁽⁸⁾	Resistor, 10k Ω , 1%, 1/16W, 0603 size	1
R2	CRCW06036200FRTI	Vishay	Resistor, 620 Ω , 1%, 1/16W, 0603 size	1
R4	CRCW06031003FRTI	Vishay	Resistor, 100k Ω , 1%, 1/16W, 0603 size	1
R5	CRCW06033092FRTI	Vishay	Resistor, 30.9k Ω , 1%, 1/16W, 0603 size	1
U1	MIC2253-06YML	Micrel, Inc.⁽⁹⁾	1MHz High Efficiency Boost Regulator with OVP and Softstart	1

Notes:

1. TDK: www.tdk.com
2. Murata: www.murata.com
3. Samsung: www.sem.samsung.com
4. AVX: www.avx.com
5. Taiyo Yuden: www.t-yuden.com
6. MCC: www.mccsemi.com
7. Coilcraft: www.coilcraft.com
8. Vishay: www.vishay.com
9. Micrel, Inc.: www.micrel.com

Recommended Layout

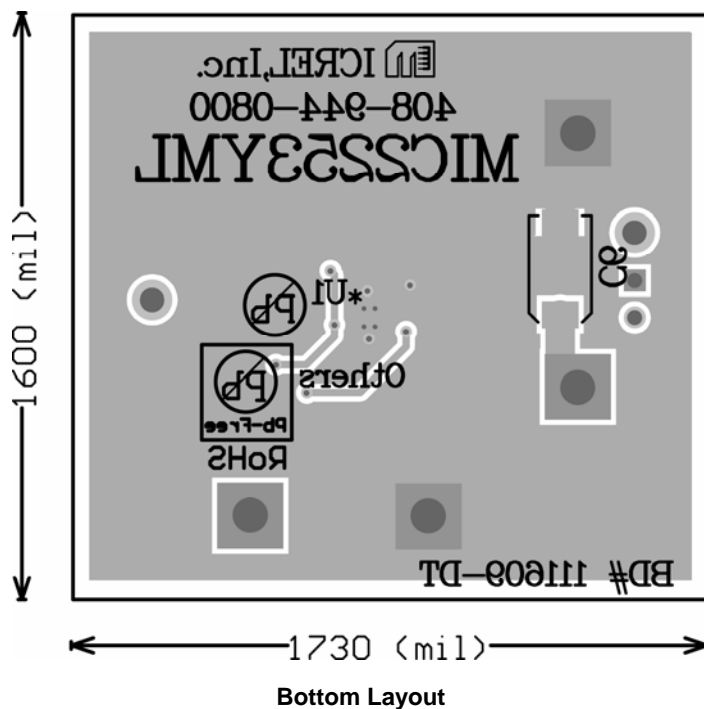
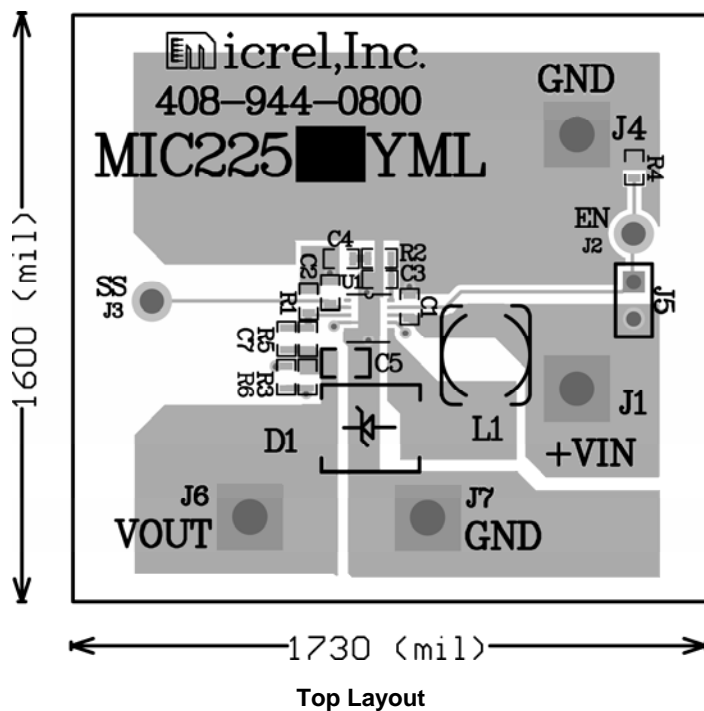

Package Information

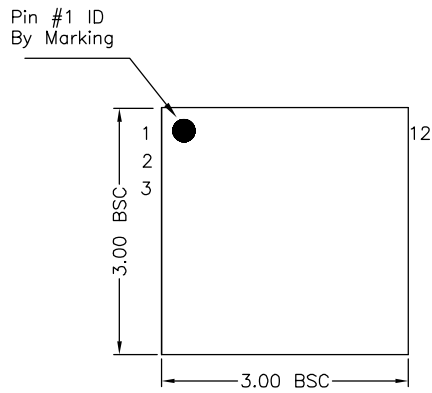

TOP VIEW

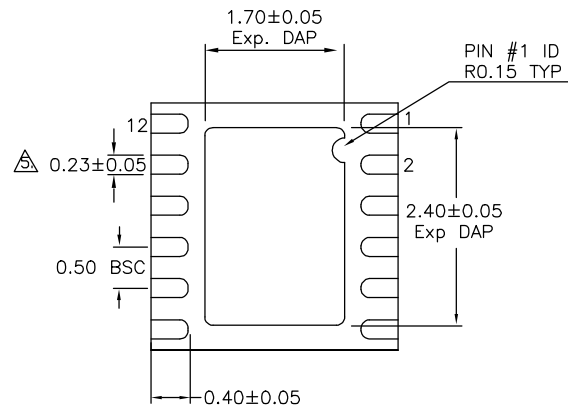

BOTTOM VIEW

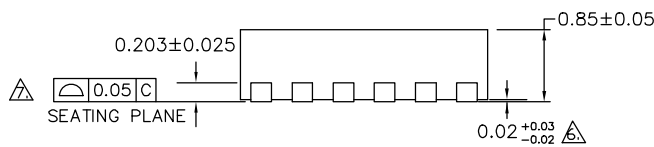

SIDE VIEW

- NOTE:
1. ALL DIMENSIONS ARE IN MILLIMETERS.
 2. MAX. PACKAGE WARPAGE IS 0.05 mm.
 3. MAXIMUM ALLOWABLE BURRS IS 0.076 mm IN ALL DIRECTIONS.
 4. PIN #1 ID ON TOP WILL BE LASER/INK MARKED. DIMENSION APPLIES TO METALIZED TERMINAL AND IS MEASURED BETWEEN 0.20 AND 0.25 mm FROM TERMINAL TIP.
- △ APPLIED ONLY FOR TERMINALS.
 △ APPLIED FOR EXPOSED PAD AND TERMINALS.

12-Pin 3mm x 3mm MLF[®] (ML)

MICREL, INC. 2180 FORTUNE DRIVE SAN JOSE, CA 95131 USA
 TEL +1 (408) 944-0800 FAX +1 (408) 474-1000 WEB <http://www.micrel.com>

The information furnished by Micrel in this data sheet is believed to be accurate and reliable. However, no responsibility is assumed by Micrel for its use. Micrel reserves the right to change circuitry and specifications at any time without notification to the customer.

Micrel Products are not designed or authorized for use as components in life support appliances, devices or systems where malfunction of a product can reasonably be expected to result in personal injury. Life support devices or systems are devices or systems that (a) are intended for surgical implant into the body or (b) support or sustain life, and whose failure to perform can be reasonably expected to result in a significant injury to the user. A Purchaser's use or sale of Micrel Products for use in life support appliances, devices or systems is a Purchaser's own risk and Purchaser agrees to fully indemnify Micrel for any damages resulting from such use or sale.

© 2009 Micrel, Incorporated.