

# SKF

---

## SKF TIH 030m



**Instructions for use**

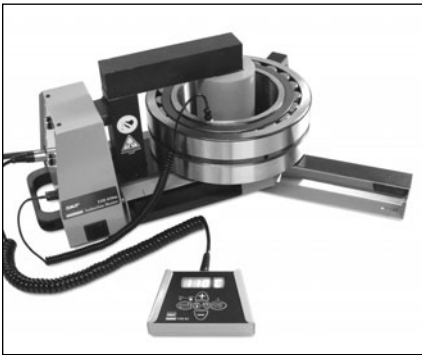

# Table of contents

<b>EU-DECLARATION OF CONFORMITY</b> .....	4
<b>SAFETY RECOMMENDATIONS</b> .....	5
<b>1. INTRODUCTION</b> .....	6
1.1 Intended use.....	6
1.2 Principle of operation.....	6
1.3 Distinguishing features .....	7
<b>2. DESCRIPTION</b> .....	7
2.1 Components .....	7
2.2 Technical data .....	8
<b>3. INSTALLATION OF MAINS PLUG</b> .....	9
<b>4. PREPARATION FOR USE</b> .....	9
<b>5. OPERATION</b> .....	10
5.1 Function of displays.....	10
5.2 Function of buttons .....	10
5.3 TEMP MODE.....	11
5.4 TIME MODE .....	12
5.5 Temperature measurement.....	12
5.6 Change of temperature unit.....	12
5.7 Demagnetisation .....	12
5.8 Power level selection.....	13
<b>6. SAFETY FEATURES</b> .....	13
<b>7. TROUBLESHOOTING</b> .....	14
<b>8. SPARE PARTS</b> .....	15

## **EU-DECLARATION OF CONFORMITY**

We, SKF Maintenance Products, Kelvinbaan 16,  
3439 MT Nieuwegein, declare that the

### **INDUCTION HEATER TIH 030m**

is designed and manufactured in accordance with the  
EUROPEAN LOW VOLTAGE DIRECTIVE 73/23/EEC  
EMC NORM 89/336/EEC,  
outlined in harmonised Norms  
VDE 0721  
EN 55011  
EN 61000-6-2  
EN 61000-3-2/3.2

The Netherlands, 20 August 2004



Ebbe Malmstedt  
Manager Product Development and Quality



## SAFETY RECOMMENDATIONS

- *Because the TIH 030m generates a magnetic field, people wearing a pacemaker must not be within 5 m (16 ft) of the TIH 030m during operation. Electronic equipment, such as wristwatches, may also be affected.*
- *Follow the operating instructions at all times.*
- *Be certain that the voltage supply is correct.*
- *Electrical arcing may occur when a potential difference exists between the TIH 030m and the workpiece. This is not dangerous to human beings and will not cause damage to the TIH 030m or the workpiece. However, the TIH 030m must never be used in areas where there is a risk of explosion.*
- *Do not expose the TIH 030m to high humidity.*
- *Never operate the TIH 030m without a yoke in position.*
- *Never operate the TIH 030m with the cable of the remote control between the vertical supports of the yoke.*
- *Do not modify the TIH 030m.*
- *Use proper handling equipment when lifting heavy workpieces.*
- *Avoid contact with hot workpieces. Wear the supplied heat resistant gloves to handle hot workpieces.*

# 1. INTRODUCTION

The SKF TIH 030m induction heater is designed to heat bearings that are mounted with an interference fit onto a shaft. The heat causes the bearing to expand, which eliminates the need to use force during installation. A 90 °C (162 °F) temperature difference between the bearing and shaft is generally sufficient to enable installation. At an ambient temperature of 20 °C (68 °F), the bearing must therefore be heated to 110 °C (230 °F).

## 1.1 Intended use

The TIH 030m has been designed to heat rolling bearings. However, other metal workpieces that form a closed circuit can also be heated. Examples of acceptable workpieces include bushings, shrink rings, pulleys, and gears. All bearings that fit over the inductive coil and between the vertical supports with the top yoke in place can be heated using the TIH 030m. In addition, smaller bearings can be placed over any of the three standard yokes. See the illustrations at the beginning of this manual for examples.

## 1.2 Principle of operation

The TIH 030m generates heat by means of a large electrical current that is magnetically induced in the workpiece by a coil within the heater. The high voltage, low current electricity flowing through the large number of windings in the inductive coil induces low voltage, high current electricity in the workpiece. Because the workpiece has the electrical characteristics of a coil with a single, short-circuited winding, the high current generates heat within the workpiece. Because the heat is generated within the workpiece, all of the heater components remain cool.

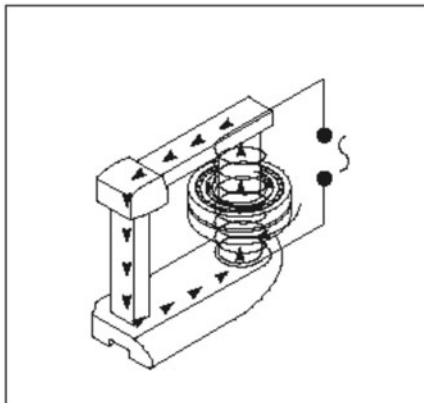

### 1.3 Distinguishing features

- Remote control panel  
To improve the ease of use and to diminish the risk of contact with the hot bearing during operation, the TIH 030m heater is supplied with a remote control panel which can be detached from the heater.
- Inductive coil  
When heated the workpiece is located at the same position on the core as the inductive coil. This design improves efficiency, resulting in less power consumption and faster heating, which reduce the cost to heat each bearing.
- Folding bearing supports  
To support large bearing positioned around the inductive coil the TIH 030m induction heater is fitted with folding bearing supports. See the illustrations at the beginning of this manual.
- Yoke storage  
All three yokes can be stored inside the heater. Two yoke storage are located behind the folding bearing supports. Storage of the small and medium yokes is in the yoke storage at the heater circuit breaker side. Storage of the large yoke is in the yoke storage at the heater mains cable side. See the illustrations at the beginning of this manual.

## 2. DESCRIPTION

The operation of the heater is controlled by the internal electronics in either of two modes. The operator can either select the desired temperature of the bearing in TEMP MODE or set the length of time that the bearing will be heated in TIME MODE. The power level can be adjusted to 100% or 50% for slower heating of sensitive workpieces (for example, bearings with C1 or C2 clearance).

### 2.1 Components

The TIH 030m induction heater contains a U-shaped iron core with an inductive coil surrounding one of the vertical supports. A detachable remote control panel is included. The remote control electronics and the internal electronics control the operation of the heater. A removable yoke on the top of the vertical supports allows the workpiece to be placed onto the heater. To accommodate smaller workpieces, two smaller yokes are also provided. A temperature probe is also included with the heater. Heat-resistant gloves are also included.

## 2.2 Technical data

### TIH 030m

Voltage ( $\pm 10\%$ )	230 V / 50/60 Hz or 110-100 V / 50/60 Hz
Recommended line protection	10 A fuse rating for 230 V 20 A fuse rating for 110 V
Power consumption (maximum)	2.0 kVA
Temperature control	0-250 °C (32-482 °F); in steps of 1°
Probe type	thermocouple, K type
Probe maximum temperature	250 °C (482 °F)
Time mode	0-60 minutes; in steps of 0.1 minute
Power range	100%- 50%
Demagnetization	automatic; residual magnetism <2A/cm
Overall dimensions (w x d x h)	450 x 195 x 210 mm (17.7 x 7.6 x 8.2 in)
Area between supports (width x height)	100 x 135 mm (3.9 x 5.3 in)
Coil diameter	95 mm (3.7 in) For minimum bearing bore diameter of 100 mm (3.9 in)
Weight (with yokes)	20.9 kg (46.0 lbs)
Workpiece maximum weight	bearing: 40 kg (88 lbs); solid component: 20 kg (44 lbs)
Maximum heating temperature m20*	approx. 400 °C (752 °F) 28 kg (bearing 23136)
Standard yoke dimensions:	For minimum bearing bore diameter of:
45 x 45 x 215 (1.7 x 1.7 x 8.4 in)	65 mm (2.6 in)
28 x 28 x 215 mm (1.1 x 1.1 x 8.4 in)	40 mm (1.6 in)
14 x 14 x 215 mm (0.6 x 0.6 x 8.4 in)	20 mm (0.8 in)

\*m20 represents the weight (kg) of the heaviest SRB 231 bearing that can be heated from 20 to 110 °C (68 to 230 °F) in 20 minutes.



### 3. INSTALLATION OF MAINS PLUG

Due to the many types of mains plugs, no mains plug is supplied with the TIH 030m. A qualified electrician must install a suitable mains plug. The correct supply voltage is shown in section 2.2.

The wires should be connected as follows:

#### TIH 030m/230V, TIH 030m/110V

Colour of TIH 030m wire	Mains supply terminal
yellow / green	ground
blue	neutral
brown	phase 1

Verify that the correct fuse is installed. See section 2.2 for fuse rating specifications.

### 4. PREPARATION FOR USE

- Place the TIH 030m in the horizontal position on a stable surface.
- Connect the mains plug to a suitable mains supply.
- Plug the remote control into the connector on the carrying handle side of the heater.
- For workpieces with an internal diameter large enough to fit over the inductive coil, follow these steps:
  - Place the workpiece over the inductive coil using appropriate lifting equipment.
  - For best performance, adjust the position of the workpiece so that the inductive coil is in the centre.
  - Position the largest yoke so that it completely covers the top of both vertical supports.
- For workpieces that do not fit over the inductive coil, follow these steps:
  - Choose the largest of the three yokes that fit through the internal diameter of the workpiece.
  - If necessary, remove the top yoke from the TIH 030m.
  - Slide the workpiece onto the yoke that you have selected.
  - Position the yoke on the TIH 030m with the bright underside resting evenly on the two vertical supports.
- If you will use TEMP MODE, plug the temperature probe into the connector on the carrying handle side of the heater. Place the magnetic end of the probe on the inner ring of the bearing or on the innermost surface of the workpiece.
- Switch on the TIH 030m.
- Observe the self-test of the remote control display and signal tone.

## 5. OPERATION

### 5.1 Function of displays

- A. The remote control display shows the selected time or temperature for heating.
- B. The power LED's show the selected power setting.

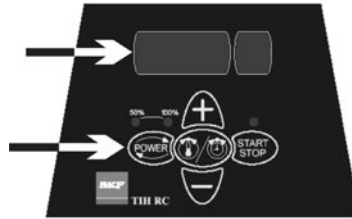

#### Display

t

°C

°F

#### Indication

time in minutes

temperature in degrees Celsius

temperature in degrees Fahrenheit

### 5.2 Function of buttons

#### Button

#### Function

POWER

Press to adjust the power. The selected power is indicated with an LED.

MODE

Press to switch between TIME MODE and TEMP MODE.

UP (+)

Press to increase the value shown on the remote control display.

DOWN (-)

Press to decrease the value shown on the remote control display.

START / STOP

Press to start or stop the heater. The LED on the START/ STOP button is lit when the heater is heating and flashes during temperature measurement.

### 5.3 TEMP MODE

- If the remote control display shows 't', press MODE to select TEMP MODE. The remote control display shows °C or °F in TEMP MODE.
- The selected temperature is shown on the remote control display. The default temperature for bearings is 110 °C (230 °F). If a different temperature is desired, press UP or DOWN to adjust the temperature in steps of 1°.
- It may be desirable to heat bearings to temperatures above 110 °C (230 °F) for increased mounting time. Consult the SKF bearing specifications to determine the maximum permitted temperature. Always ensure the bearing does not lock due to an excessive expansion of the inner ring compared to outer ring. See section 5.8.
- If needed press POWER to select the power level. Use the guidelines in section 5.8 to determine the correct power setting.
- Make sure the temperature probe is mounted on the bearing inner ring.
- Press START/STOP to start the heater. The remote control display shows the current temperature of the workpiece.
- During heating the selected temperature can be displayed for 1 second by pressing MODE.
- When the selected temperature has been reached, the heater demagnetises the workpiece, switches off, and generates an acoustic signal for 10 seconds or until START/STOP is pressed.
- Press START/STOP to stop the heater.
- Remove the workpiece with proper handling equipment.
- If the workpiece remains on the heater, the heater will start again when the temperature of the workpiece drops 10 °C (18 °F). Press START/STOP to stop the heater and demagnetise the workpiece.
- The TIH 030m is now ready to heat another workpiece with the same settings.

## 5.4 TIME MODE

- If the remote control display shows °C or °F, press MODE to select TIME MODE. The remote control display shows 't' in TIME MODE.
- Press UP or DOWN to adjust the time in steps of 0.1 minute.
- Press POWER to select the power level. Use the guidelines in section 5.8 to determine the correct power setting.
- Press START/STOP to start the heater. The remote control display shows the time that remains.
- During heating the temperature measured by the probe can be displayed for a couple of seconds by pressing MODE.
- When the time has elapsed, the heater demagnetises the workpiece, switches off, and generates an acoustic signal for 10 seconds.
- Press START/STOP to cancel the acoustic signal and stop the heater.
- Remove the workpiece with proper handling equipment.
- The TIH 030m is now ready to heat another workpiece with the same settings.

## 5.5 Temperature measurement

When the heater is not operating, the temperature of the workpiece can be measured by pressing MODE and START/STOP at the same time. The LED on the START/STOP button flashes during temperature measurement. Press START/STOP to cancel temperature measurement.

## 5.6 Change of temperature unit

Press MODE and UP at the same time to switch between °C and °F. The temperature unit setting remains the same even after disconnection from mains power.

## 5.7 Demagnetisation

The workpiece is automatically demagnetised when heating is complete. Demagnetisation will not occur if the power is interrupted or the main switch is switched off. To use the TIH 030m for demagnetisation only, select TIME MODE and set the time to 0.1 minute (6 seconds).

### **5.8 Power level selection**

When heating bearings with an induction heater, most of the heat will be generated in the inner bearing race. The heat will then be transferred through the bearing. It is therefore important that bearings with small internal clearance or slight preload are heated slowly. Slow heating ensures that the bearing expands evenly, thereby preventing damage to the bearing.

The shape, weight, size, and internal clearances all affect the amount of time required to heat a bearing. The large variety of bearing types precludes the possibility of providing a specific power level setting for each type. Instead, the following guidelines are provided:

- For sensitive bearings (including bearings with C1 or C2 internal clearance) or bearings with brass cages, do not exceed 50% power.
- When using the small yoke, never exceed 50% power.

## **6. SAFETY FEATURES**

The TIH 030m is equipped with the following safety features:

- Automatic overheating protection
- Automatic current control
- Over-current circuit breaker.
- In the TEMP MODE the heater will switch off if the temperature probe does not register a temperature increase of 1°C (1.8°F) every 15 seconds (0.25 minute). To increase the interval to 30 seconds (0.50 minute), press MODE and DOWN at the same time.

## 7. TROUBLESHOOTING

A system fault will be indicated by an acoustic signal and one of the following fault codes on the remote control display:

<b>Display</b>	<b>Fault</b>	<b>Action</b>
E03 E	Overheated coil	Wait until the inductive coil cools. Switch the heater OFF and then back ON.
E05 E	Temperature increase of less than 1°C (1.8°F) every 15 seconds (or 1° every 30 seconds)	Check the temperature probe connection. If the connection is OK, select the 30 second interval as described in section 6 or operate the heater in TIME MODE.
E06 E	Temperature probe not connected (or defective) or excessive temperature drop.	Check the temperature probe.
E10E	Electronics communication problem	Switch the heater OFF and then back ON. If problem remains return the TIH to SKF for repair.
E11E	Electronics communication problem	Switch the heater OFF and then back ON. If problem remains return the TIH to SKF for repair.
E12E	Electronics communication problem	Switch the heater OFF and then back ON. If problem remains return the TIH to SKF for repair.

## 8. SPARE PARTS

TIH 030-P230V	Power print 230V - 220-240V, 50-60 Hz
TIH 030-P110V	Power print 110V - 100-120V, 50-60 Hz
TIH 030-Y7	Yoke 45x45x215mm
TIH 030-Y6	Yoke 40x40x215mm
TIH 030-Y4	Yoke 28x28x215mm
TIH 030-Y3	Yoke 20x20x215mm
TIH 030-Y2	Yoke 14x14x215mm
TIH 030-YS	Support yoke set - 45x45x100 mm (2x)
TIH CP	Control print
TIH RC	Remote control
TIH CB10A	Circuit breaker 10A for TIH 030M/230V
TIH CB20A	Circuit breaker 20A for TIH 030M/110V
TIH P2A	Temperature probe K type incl. cable and plug

*In line with our policy of continuous development of our products we reserve the right to alter any part of the above specification without prior notice.*

**SKF Maintenance Products**  
© Copyright SKF 2004/09

[www.mapro.skf.com](http://www.mapro.skf.com)  
[www.skf.com/mount](http://www.skf.com/mount)

MP5297